



MAKING YOUR DREAMS A REALITY

## FITTING INSTRUCTIONS

**TYLY-0326 RC36-2 Hub Conversion Assy.**

**NC30 Hub & RC30 Single Nut Wheel**



<b>Code</b>	<b>Product Name</b>	<b>Qty</b>
TYLY-0326A	Bracket, Rear Brake, Pro-Arm Underslung Caliper, NC30 Eccentric, Single Nut Wheel, RC36-2	1
TYLY-0326B	Stopper, Bracket, Pro-Arm Underslung Caliper, NC30 Eccentric, Single Nut Wheel, RC36-2	1
TYLY-0326C	Spacer, Disc, Pro-Arm Underslung Caliper, NC30 Eccentric, Single Nut Wheel, RC36-2	1
TYLY-0326D	Threaded Insert, Disc, Pro-Arm Underslung Caliper, NC30 Eccentric, Single Nut Wheel, RC36-2	4
TYLY-0326E	Spacer, Sprocket Carrier, Pro-Arm Underslung Caliper, NC30 Eccentric, Single Nut Wheel, RC36-2	1
TYLY-0326F	Hub Adapter, Pro-Arm Underslung Caliper, NC30 Eccentric, Single Nut Wheel, RC36-2	1
TYLY-0326G	Bush, 6mm x 13.5mm x 2mm - Spacer for 95701 bolt	4
TYLY-0326H	CHST-1030F - M10x30 Cap Head Black, drill hole	1
SERV-0001	Modify Eccentric Hub and fit TYLY-0326F and 2x THST-0625 - Service	1
SERV-0002	Modify Customer Nut. Modify thickness and zinc plate - Service	1
NUBO-0007	Split Pin 2.5x20	1
BPSY-0381	Guide, Brake Hose, Pro-Arm	1
96300-08020-00	Bolt, Flange, M8x20	2
95701-06018-00	Bolt, Flange, M6x18	4
THST-0625	Taperhead M6x25, Silver.	2
NUBO-0008	<i>Split Pin 3x30</i>	1



## TYLY-0326 Assy. Parts

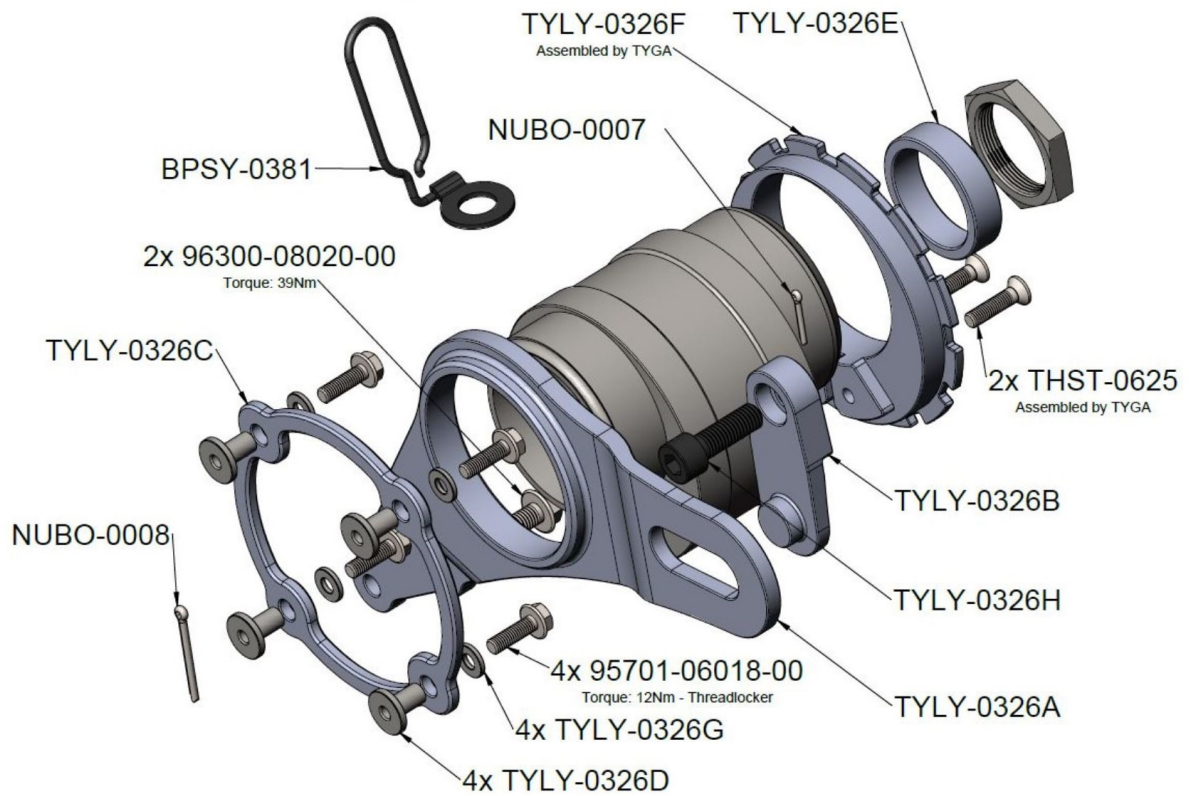

## OEM parts modified by TYGA

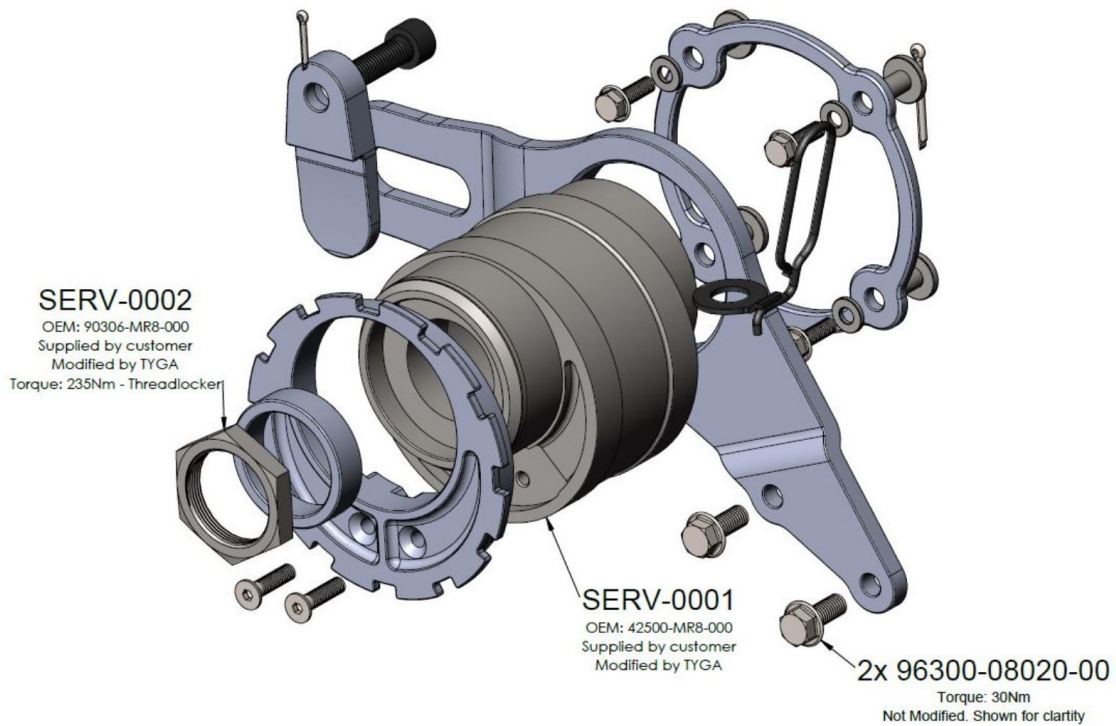



One of the fundamental visual differences between the RC36-2 and the RC30 is the rear wheel. The R36-2 uses a four hole bolt pattern, while the RC30 uses a single nut to hold it in place.

Our mission was to take an RC30 wheel and fit it to the RC36-2 using a mixture of VFR400R NC30 rear hub parts, an underslung rear brake caliper and a handful of CNC parts.

There are a number of parts on the standard RC36-2 that need changing for this conversion, but we have tried to make it as simple as possible. This is a straight forward "bolt-on" solution, with no modifications necessary to the standard bike, so this is 100% reversible should the need or desire arise.

Before we go too far, there are some parts that the customer will need to source for this conversion, and a couple of those parts will need to be sent to TYGA for modification.

The important parts to get this conversion underway are the NC30 Eccentric bearing holder (42500-MR8-000), and the Big M38 nut (90306-MR8-000) that holds the sprocket carrier on. We need to machine the eccentric and then press fit the TYLY-0326F hub adapter.



The sprocket carrier nut requires that the 'skirt' is cut off and the nut machined to the same thickness as the RC30 nut. It is then zinc plated to resist corrosion. Note that we do not drill holes in the nut for lockwire, instead we recommend that the nut is fitted using threadlocker to retain it.

There are also some RC36-2 parts that you need to keep for the conversion. The RC36-2 rear disc and also the large 75mm circlip that retains the brake caliper bracket onto the eccentric. The standard RC36-2 disc is used due to the NC30 disc being too small in diameter, which causes interference between the brake caliper and the swingarm.

Wheel choice is up to the end user, but for an RC30 tribute there was no contest but to fit a standard 5.50x18" RC30 wheel. The tyre fitted to the RC30 wheel is a 180/55 ZR 18, and measures 184mm wide when fitted to the wheel. This is as wide as is physically possible to fit without the tyre rubbing on the swing arm, so please pay careful attention to this.

Other single nut wheels can be fitted such as our own 5.5"x17" PVM wheel. And of course Honda single nut wheels such as NC30 (18") or NC35 (17") will also fit, but at 4.5" rim width, these are perhaps a little small. However, various sources do say that it is acceptable to fit a 170/60-18 or 180/60-17 tyre on these 4.5" rims. Please verify this with your tyre supplier before fitting.

Concerning sprockets and final ratio of the gearing. The standard RC36-2 is fitted with a 17" wheel and uses 16T/43T final gearing. If keeping a 17" wheel then the gearing could stay as is. In our case with the RC30 wheel, the rolling radius is different to the 17" standard wheel, so to keep the same final ratio the same as stock we designed a special #530 45T offset sprocket that is a simple bolt on, and designed to line up with the standard 16T front sprocket. On our bike it fits, and adjusts nicely with the standard #530 chain.

Wheels and sprockets are quite a complex subject, so we have prepared a separate document explaining different gearing choices depending on what wheels are used, so please check that out.

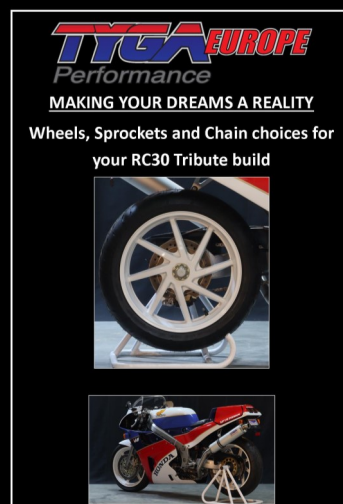

With the introduction out of the way, let's move on to getting the conversion done.

First and foremost, we need to talk about safety of course, as during this conversion, and depending on the state of assembly of the bike, you may have to find some rather clever solutions for holding it upright in a safe and sturdy manner. Make sure that bike is always secure and won't suddenly fall over, and that any stands used are more than strong enough to hold the bike.

In our case, we have our TYGA steps fitted which have rigid pegs, so we can hold the rear wheel off the ground by using axle stands under the pegs, with rubber pads between the stands and the aluminium footpegs for protection. This allows us to remove all the rear hub components in one go.

Concerning special tools, you'll need a couple of rather large sockets. Specifically, 46mm for the sprocket carrier nut and 36mm for the new wheel nut. The standard RC36-2 wheel nuts are 19mm, which is a common size in most socket sets available. I advise using a 19mm socket with a 1/2" drive. Other specialised tools that make the job easier are big external circlip pliers and a chain adjusting tool. As you own an RC36-2 then you probably have the chain adjusting tool, but if not then we have

TYTO-0027 Pro Arm chain adjusting tool which is perfect for the job.



I also advise applying Loctite 263 high strength threadlocker to various fasteners, and I will note this in the instructions where it is important.



Before lifting the bike into the air, we should loosen off a few components, and this is best done while the bike is on the floor. The two most difficult fasteners to loosen are the 4x nuts that hold the wheel onto the hub, and the sprocket carrier/cush drive nut. Generally, the easiest way is to use the biggest friend you can find to sit on the bike, put the bike into first gear and then jam the rear brake on. The wheel nuts are not too difficult, but the sprocket carrier nut can be a bit tricky, especially if it hasn't had any maintenance over the years. All you need to do at this stage is just loosen the fasteners enough so that you can remove easily when the bike is on the stands. My usual plan is to soak everything in penetrating fluid for a couple of days before I plan to do it.

Let us assume that we now have the rear end off the ground using axle stands under the foot pegs. This way we have total access to all the components of the rear hub and can do the job start to finish.

I will summarize the removal of the standard components in just a few steps.

- 1)** Remove the rear wheel.
- 2)** Remove the chain guard. It makes access a little easier.
- 3)** Remove the rear brake caliper. First remove the M10 bolt that secures the brake torque arm to the swingarm. There's a split pin that needs removing first. Then there are two M8 bolts holding the caliper to the carrier. The caliper should now lift off the disc. It is also a good idea to either remove the brake line from the master cylinder or remove the complete master cylinder as an assembly with the line and caliper.
- 4)** Loosen the eccentric hub pinch bolt and adjust so that the chain is at its slackest point. Take the chain off the rear sprocket if possible.
- 5)** Remove the nut and washers holding the sprocket carrier/cush drive on and remove as an assembly.
- 6)** The centre axle/disc assembly is now free to slide out of the right side of the eccentric.
- 7)** Remove the big circlip on the right side of the eccentric that secures the brake caliper carrier. We will reuse this circlip during assembly.
- 8)** Remove the brake caliper carrier.
- 9)** The final piece of the puzzle is the eccentric. This can sometimes be a little difficult to remove due to possible debris that has found its way inside the swingarm. Please do not try to force the eccentric out or it could be damaged. Gentle wriggling usually does the trick here.



**10)** There is actually one more job and that is to remove the standard RC36-2 disc from the axle. As mentioned previously, we will reuse the disc on the NC30 axle.

So now that we have all the components removed you will probably want to have a clean up of the swingarm, as you have good access to all areas!

We will start the assembly process from the 'naked' swingarm and go from there.



**1)** First job is to fit the stopper TYLY-0326B. This part self locates on the machined step. Secure with the M10x30 bolt. Torque to 35Nm. Insert the split pin through the hole as shown.

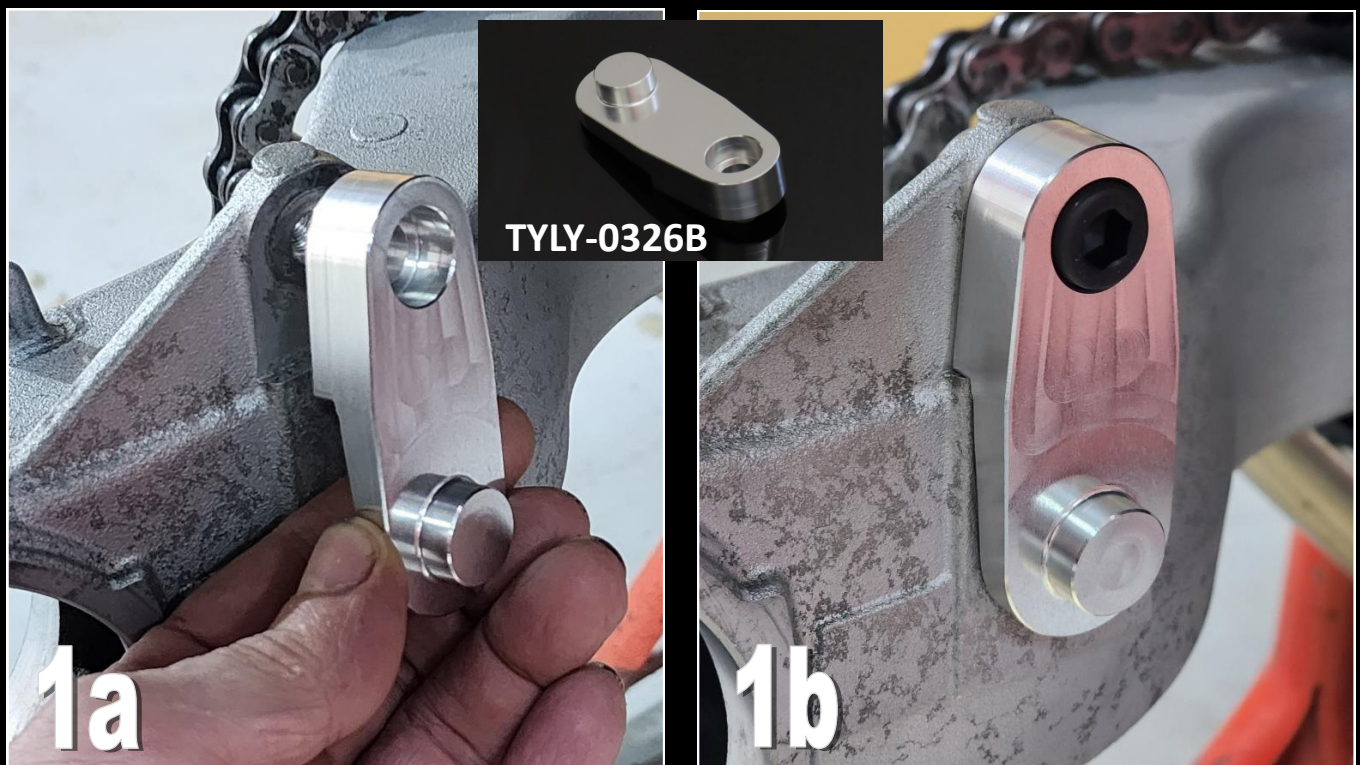





**2)** Now prepare the modified NC30 eccentric. Fit the spacer TYLY-0326E on the left side. The seal will hold it in position. Now slide it into the swingarm from the left side. Note that the bearings should be on the top side, so fit with the bearings at around the 12 o'clock position. It is a good idea to tighten the pinch bolt just a little at this point to stop the eccentric from moving around.

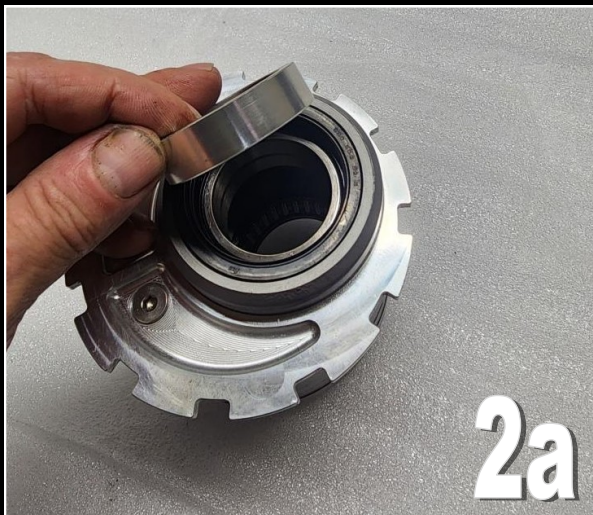
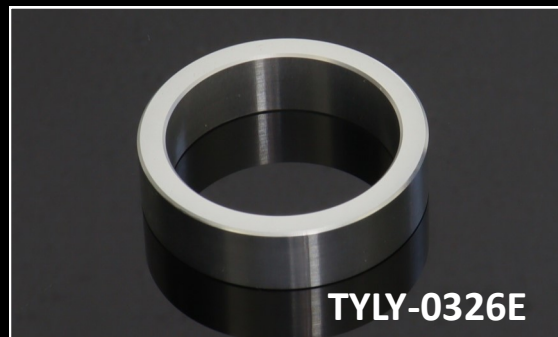



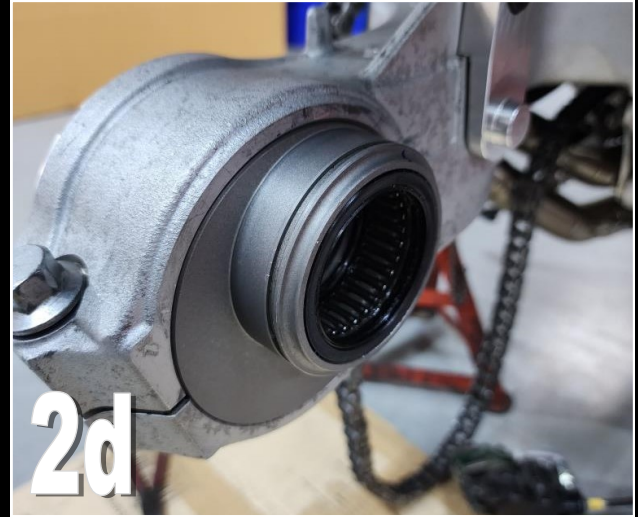
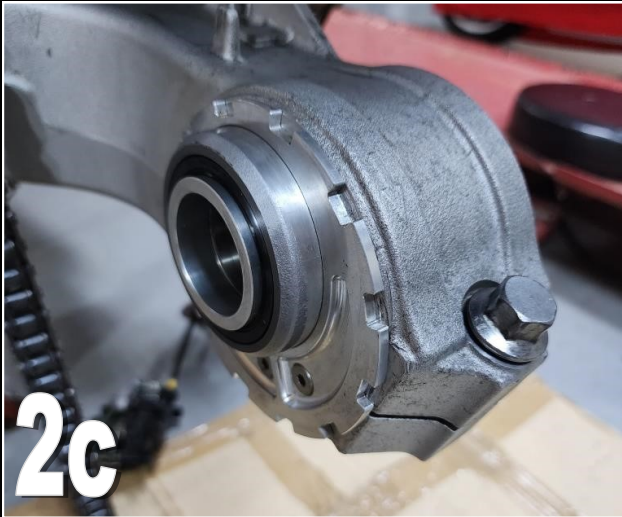

Fit the caliper hanger bracket TYLY-0326A into position and locate the slot onto the stopper. The bracket is then retained in position by the large circlip.



Take a close look at the circlip and you will see that one side has sharp edges and the other side has slightly smooth rounded edges due to the stamping process used to manufacture the part. Fit the circlip with the sharp edges facing outwards. This gives maximum security for staying in place in the groove, and smoother side of the circlip is less likely to mark the hanger bracket. Double benefit!



4) Now we need to work on assembling the axle components. Prepare the parts as shown



Hold the R36-2 disc in the vice with soft jams to avoid any damage





Turn your attention to the NC30 axle and fit the 4x TYLY-0326D threaded inserts.



Now prepare the 4x 95701-06018-00 M6 bolts and fit the TYLY-0326G 2mm spacers.



Offer up the TYLY-0326C spacer onto the axle and locate on the threaded inserts.

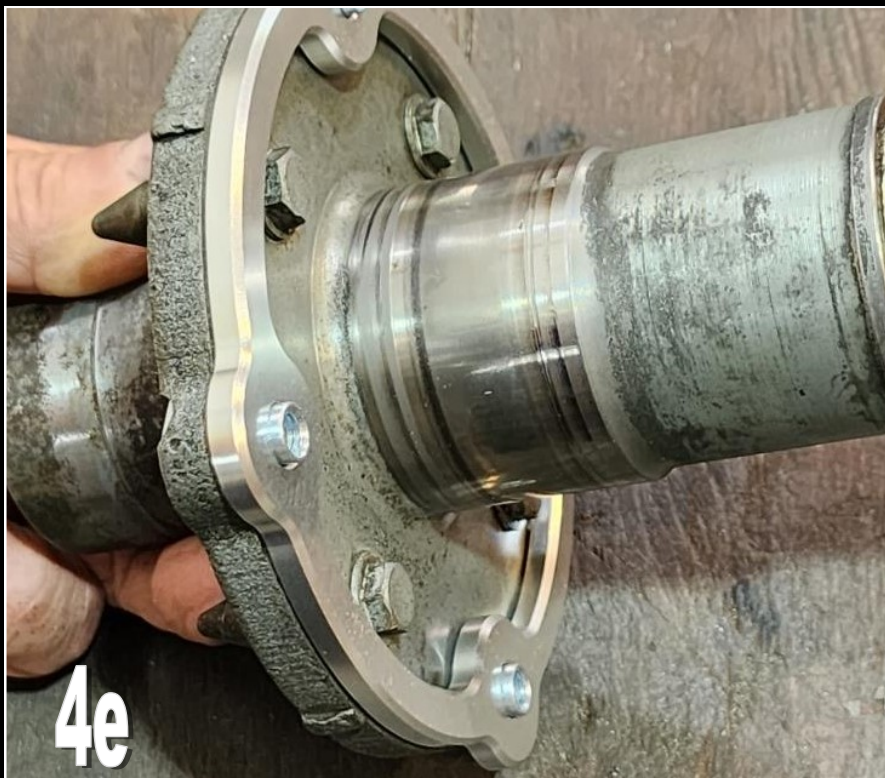



Locate the axle assembly onto the disc and screw in at least one of the M6 bolts to loosely secure the assembly in position.

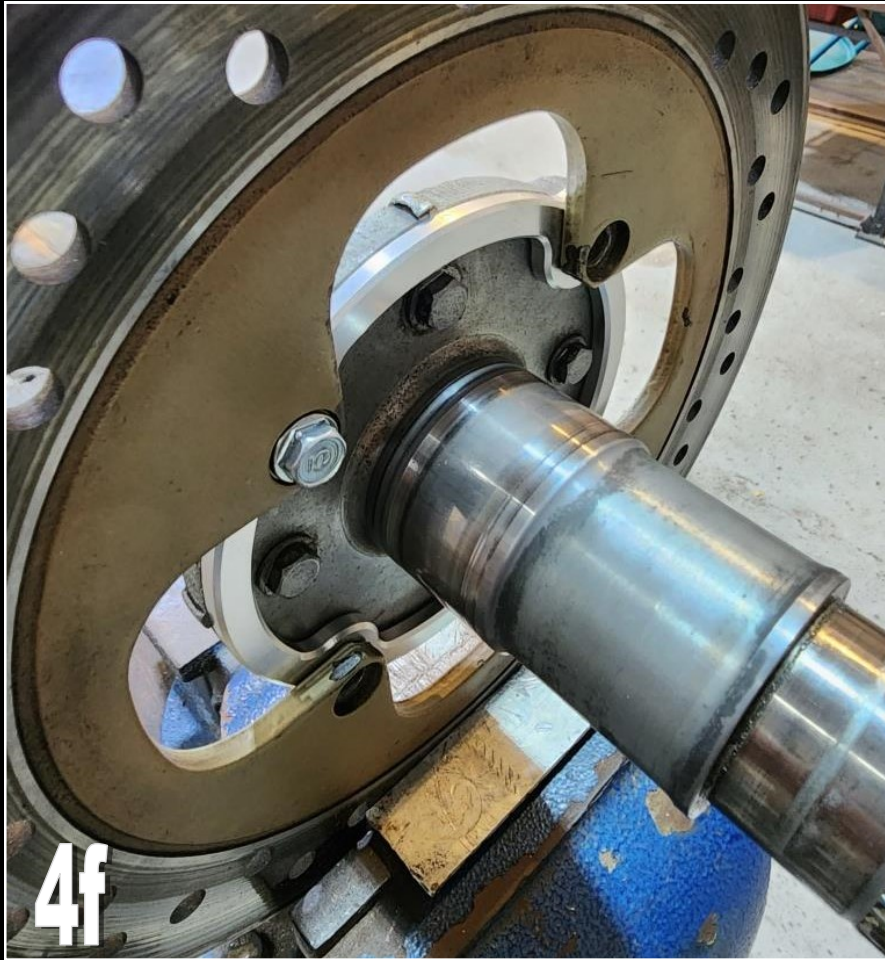

Add a drop of threadlocker to each M6 bolt and screw into the threaded insert. Don't forget to remove the first bolt fitted, apply threadlocker and refit. Torque to 12Nm.

If the insert tends to spin so that you cannot reach the correct torque setting, insert a small flat blade screwdriver into the cutout on the rear side of the insert to stop the insert from rotating.

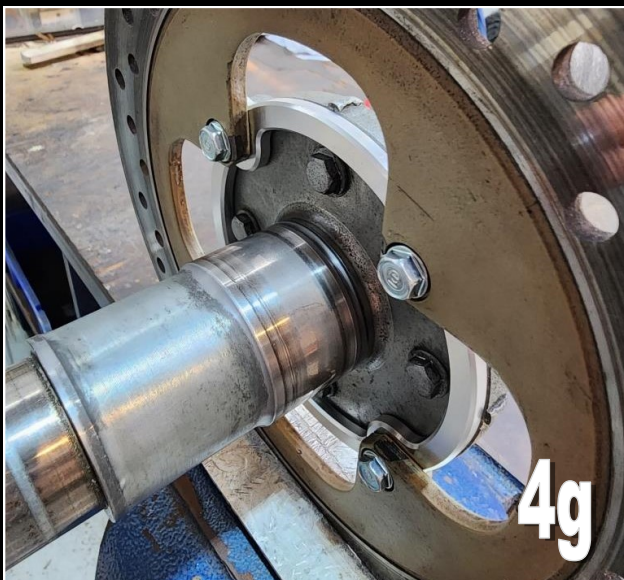



**5)** Apply grease to the needle bearing in the eccentric, and also a light smear of grease on the axle, and fit the assembled axle into the eccentric.

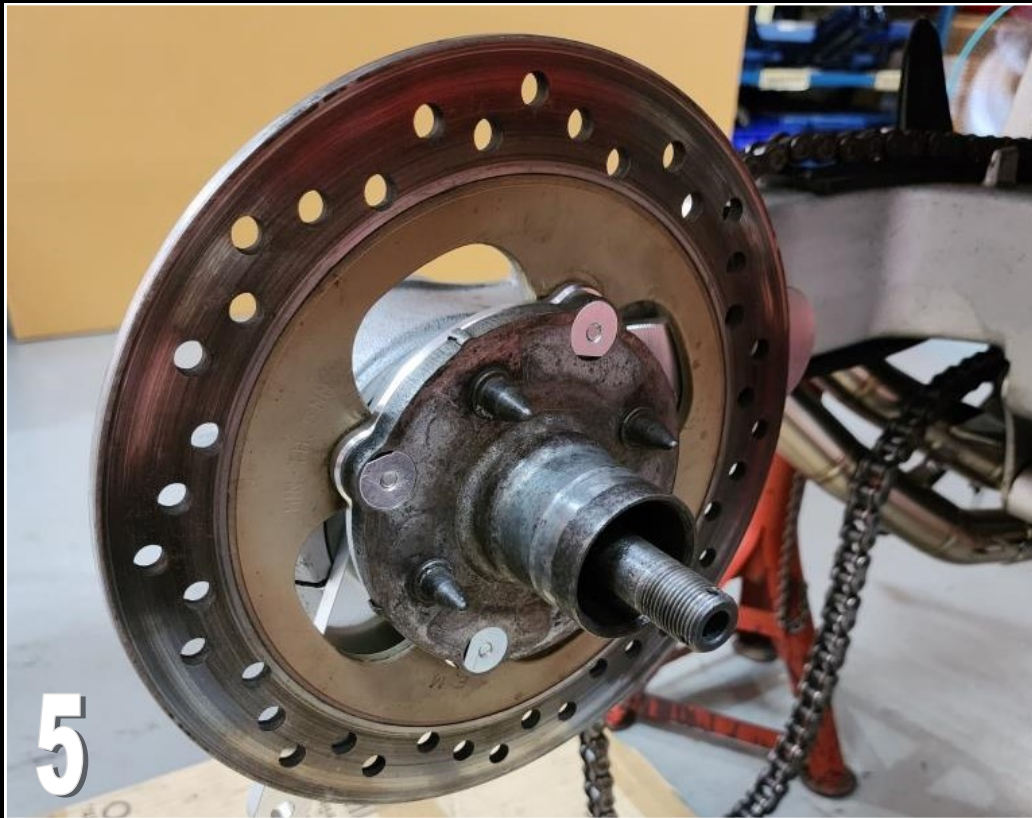

**6)** We are now ready to fit the sprocket carrier.  
Make sure that the TYLY-0326E spacer is fitted.

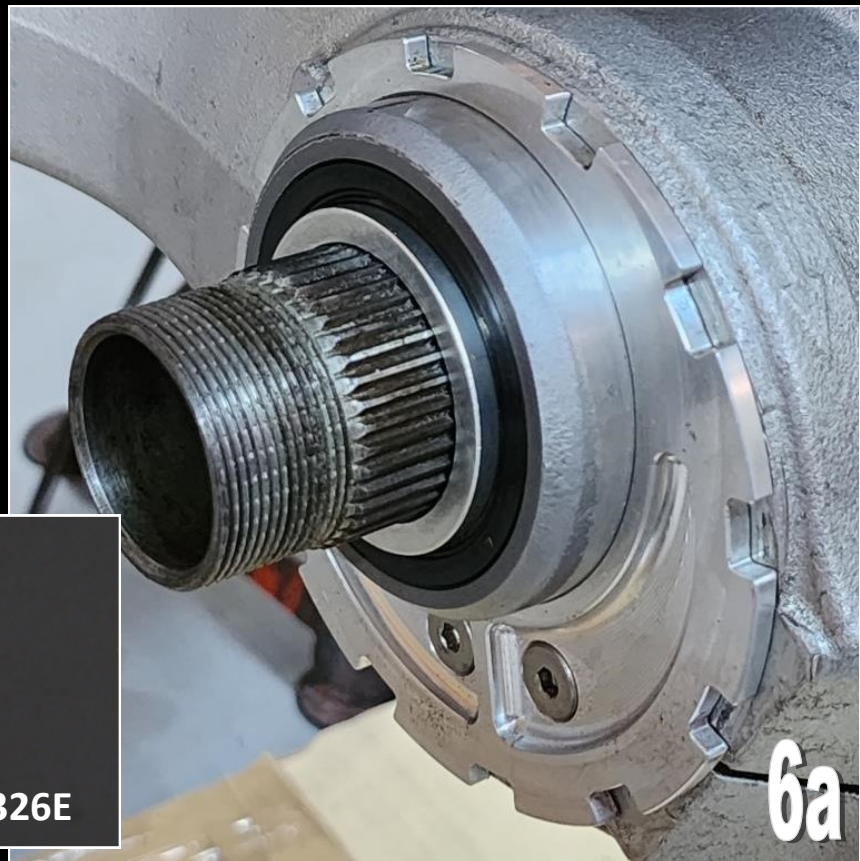



The sprocket should be already mounted to the carrier. Torque the M8 bolts to 33Nm.  
Then fit the carrier onto the splines of the axle.

Note that the sprocket shown in the picture is a prototype 45T offset sprocket  
(TYSR-0549-45T). The production version will be anodized black.

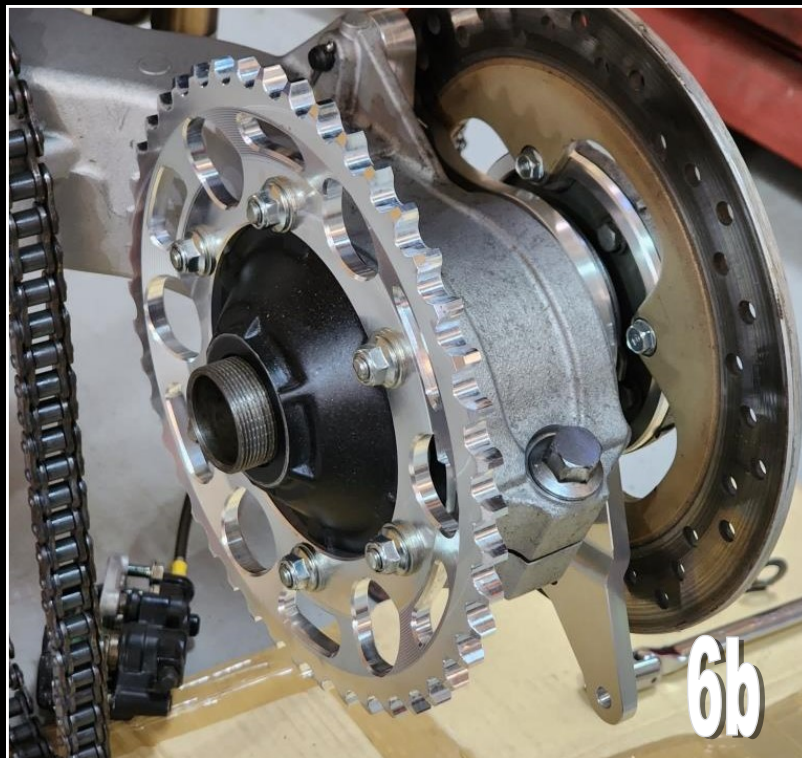

**7)** Now fit the thin shim, locking washer and finally the nut. The nut shown is a standard NC30 nut that has been machined to the same dimensions as the RC30 nut. It does not have the lock wire holes, so it is imperative that this nut is tightened to the correct torque and that threadlocker is used. Torque to 235Nm.



**8)** The underslung style rear brake caliper can now be fitted. Nothing particularly difficult here. Just slide the disc between the pad, line up the mounting bosses on the caliper with the mounting holes on the hanger bracket and fit the 96300-08020-00 M8x20 bolts.

Torque these M8 bolts to 30Nm.

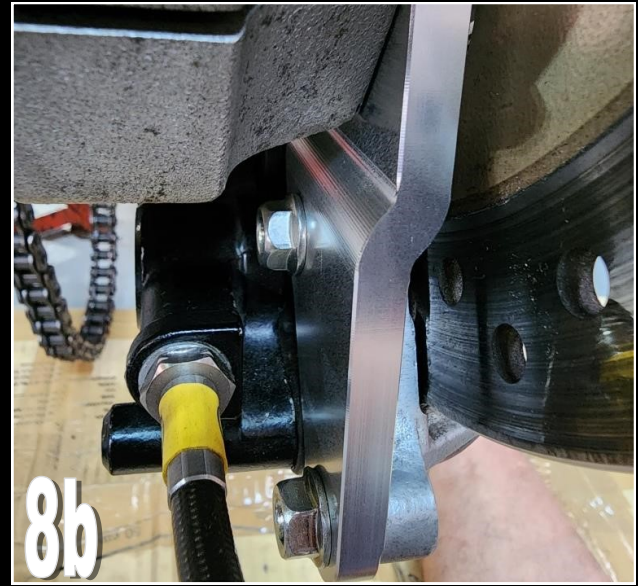
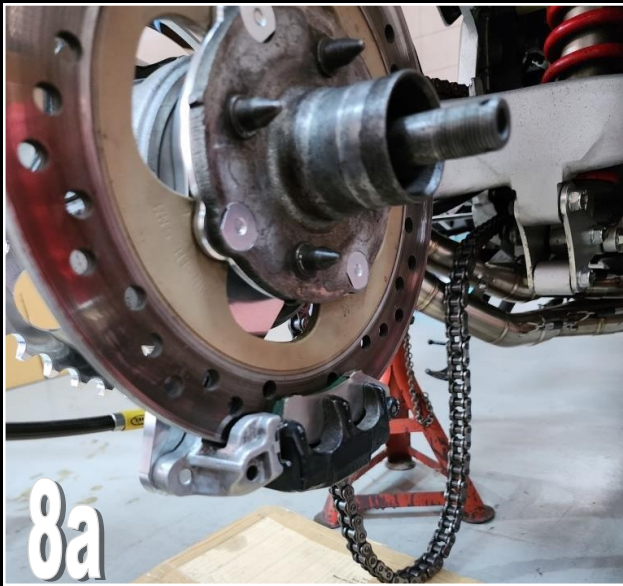

**9)** Fit the BPSY-0381 Hose Guide to the rear hub pinch bolt and thread the hose through.

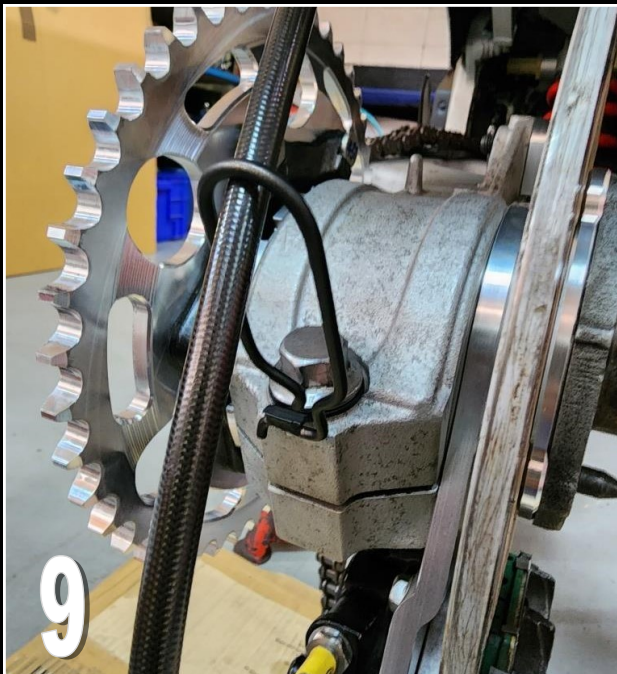



**10)** Re fit the chain guard and route the rear brake hose though the holders. There's also a little hook under the battery box area.



**11)** Adjust the chain tension following the guidelines in the service manual or on the decal on the chain guide. Recommended 20mm. free play. Tighten the pinch bolt to 55Nm.

**12)** Now would be a good time to just go over all the nuts and bolts again just to be 100% sure that everything is tight, and nothing forgotten.

**13)** Finally you can now fit the rear wheel. A tapered spacer is required for the RC30 wheel. We use the standard RC30 part, or you can use TYLY-0196 Spacer, Center Lock, Taper Fit. This spacer is followed by a thin shim and then the castellated nut. Torque the nut to 110Nm and finally fit a split pin for security.







14) All done!



[www.tyga-europe.com](http://www.tyga-europe.com)